

冷轧滚珠丝杠+5相步进电机 / Rolled Ball Screw + 5-Phase Stepping Motor

# TMB □24 / NEMA 10

Shaft dia. (轴径) f6

【TMB0601 / TMB0602】

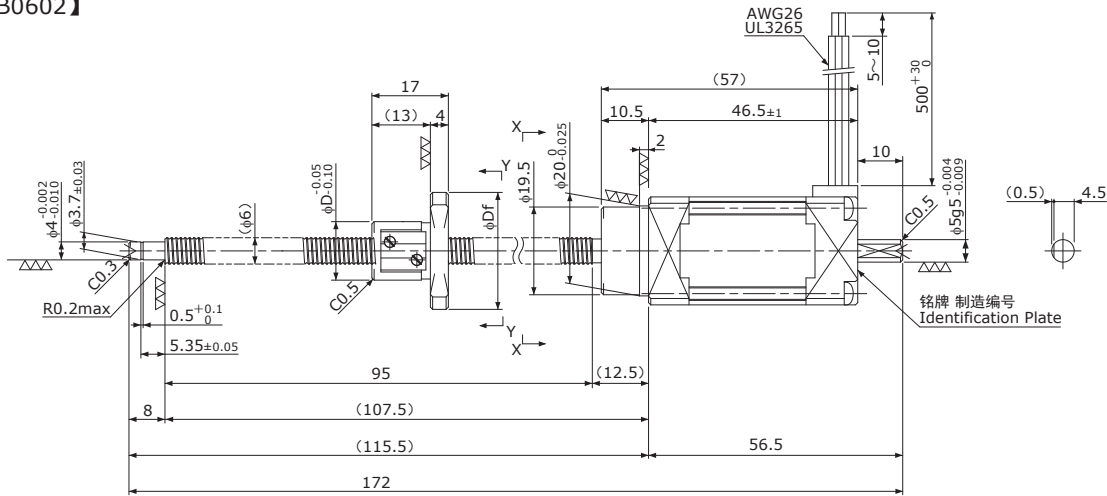

【TMB0606】

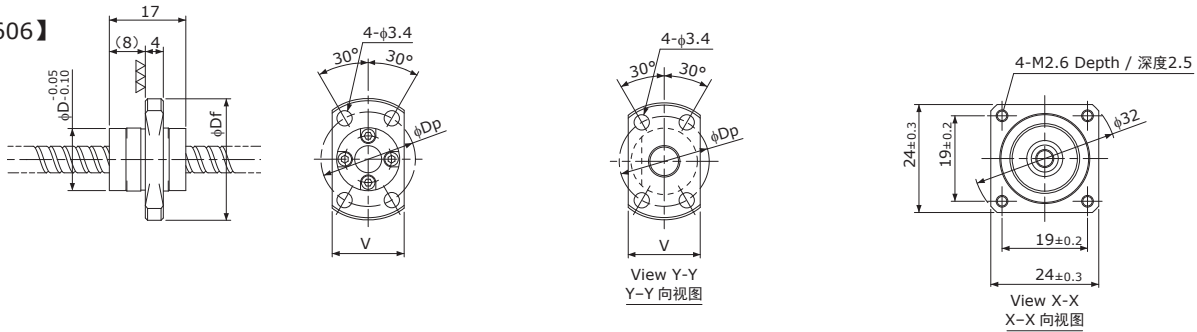

Unit(单位):mm

Model 型号	Lead 导程	Travel 行程	Reference Thrust 参考推力 (N)	D	Df	V	Dp	Mass 质量 (g)
TMB0601	1	75	100	13	26	16	20	180
TMB0602	2	75	50	15	28	19	22	180
TMB0606	6	75	15	14	27	16	21	180

Recommended Drivers 推荐驱动器	KR-A5CC KR-A55MC(Micro step) KR-A535M(Micro step / AC-100~220V)
------------------------------	---

Note) Refer to page P162 or P163 for connection diagram of recommended Drivers.  
注) 有关与推荐驱动器的接线, 请参照P162或P163页。

Ball Screw Specifications	滚珠丝杠主要技术参数
Accuracy grade 精度等级	JIS Ct7
Thread direction 旋向	Right 右
Axial play 轴向间隙	0.020mm or less 0.020mm以下
Shaft & Nut material 丝杠轴、螺母材质	Chrome-molybdenum steel 铬钼钢
Surface Coating 表面处理	Black Chrome coating on Shaft 丝杠轴采用黑铬处理
Surface hardness 螺纹部表面硬度	HRC58~62 (Thread area)
Lubricant 润滑剂	KSS original grease MSG No.1 KSS原装油脂 MSG No.1

Motor Specifications	电机参数
Basic step angle 基本步进角	0.72°
Rated Voltage 额定电压	DC 1.28 V
Rated current 额定电流	DC 0.75 A/phase DC 0.75 A/相
Winding resistance 绕组电阻	1.7Ω
Holding Torque 保持扭矩	0.028Nm
Rotor inertia 转子惯量	TMB0601, TMB0606: 8.8g·cm <sup>2</sup> TMB0602: 8.7g·cm <sup>2</sup>
Operating temperature 使用温度范围	-20°C~50°C

Note) Only shaft end cutting is available.  
Other than that, it would be customized order.  
注) 只能裁切轴端。  
其他轴端形状为定制产品。