

Lead Screws with Plastic Nuts

Resin Lead Screws

● Features

- The Shaft is manufactured from SUS304 (or SUS303), which gives excellent corrosion resistance.
- Wide range of combination of Shaft dia. and Lead are available.
- MRH incorporates a lubricating agent so it can be used without oiling. It is possible to obtain smooth movement with lubricant.
- Uses the same gothic arc grooves as Ball Screws, ensuring smooth transmission.
- MRH is standard in stock, but Nut material can be changed to order, based on the environmental condition.
- Selecting backlash free type, Axial play can be 0.



● Type

Customized products

MRH-A,B series : KSS products

A Polyamide type Resin with good sliding properties is employed in the standard MRH Nut material. And because a lubricating agent is incorporated in the material, it can be used without oiling. Additionally, other Nut materials are available as options.



Customized products

MRH-BP2 series : KSS products

A Polyamide type Resin with good sliding properties is employed. Backlash free construction made possible with Double Nuts and a Spring in between.



Customized products

R-MSS(Y) series : NTN Corp. products

Corresponding to a wide range of environment and having corrosion resistance, heat resistance. High lead types (3 times as dia.) are available.

● Combination of Shaft nominal dia. & Lead

Unit: mm

Shaft dia. \ Lead	1	2	5	6	8	9	10	12	15	18	20	24	30	36
4	D109	D109												
6	D109	D105 D106 D109		D105 D106		D105 D106 D109				D109				
8	D109	D105 D106 D109	D105 D106		D105 D106			D105 D106 D109				D109		
10		D105 D106 D109		D105 D106			D105 D106		D105 D106 D109		D105 D106		D109	
12		D105 D106 D109		D105 D106			D105 D106			D109	D105 D106		D105 D106	D109

Note1) The numbers in each cell show pages in the catalogue. D105 and D109 are for back lash type, D106 is for backlash free type.

● Specifications

Accuracy grade and Axial play

Accuracy grade of KSS Resin Lead Screws is based on JIS Ct10. Tolerance on specified travel is calculated by following formula.

Axial play is 0.05 to 0.10mm (except Backlash free type).

$$\text{Tolerance on specified travel } \epsilon_p: \epsilon_p = \pm \frac{\ell_u}{300} \times 0.21 \text{ (mm)}$$

ℓ_u : Useful travel (mm)

Material

Parts	Material
Shaft	SUS304 or SUS303
Nut	MC nylon (MC703HL) Mitsubishi Chemical Advanced Materials

Note 1) Please refer to page D104 for Nut material suitable for special environment.
Note 2) If material other than the table is requested, please inquire KSS

Description of Run-out and location tolerance

Description of Run-out and location tolerance for KSS Resin Lead Screws is as follows.

Each part of Run-out tolerance is based on JIS Ct10 of Ball Screws.

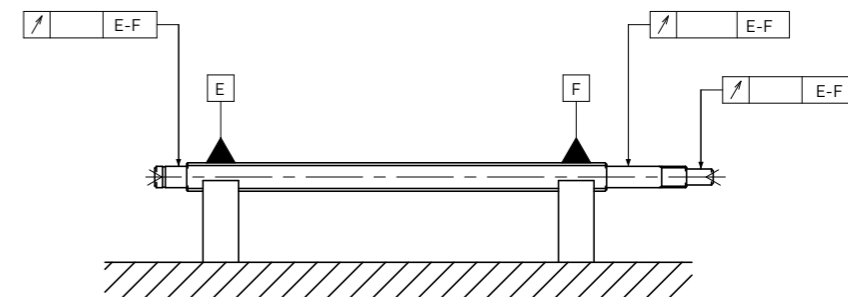

● **Technical Data**

Thread groove profile

The thread grooves are of a gothic arc design. This is basically the same as those used in our Ball Screws.

Mechanical efficiency

Mechanical efficiency of KSS Resin Lead Screws η (%) can be calculated by the following formula.

The expected "Mechanical efficiency" calculated from measurements is 20%-50%.

Generally, as the Lead increases, "Mechanical efficiency" tends to be high. Please use this number as a reference.

$$\eta = \frac{F_a \times \ell}{T \times 2\pi} \times 100 \quad (\%)$$

F_a : Axial load(N)
 ℓ : Screw Lead(m)
 T : Rotational torque(Nm)

FV value limits on use and endurance data

• FV value limits on use

For KSS Resin Lead Screws, the product of Axial Load and relative velocity of Screw surface is defined as FV, and this definition is reference to check if it is usable or not. Fig. D-11 is maximum FV which can be operated without lubricants in case of using Nut material MRH(Material : MC703HL).

Please use it as one of the reference. It is expected to improve operational condition by applying lubricants.

Fig. D-11 : FV value limits

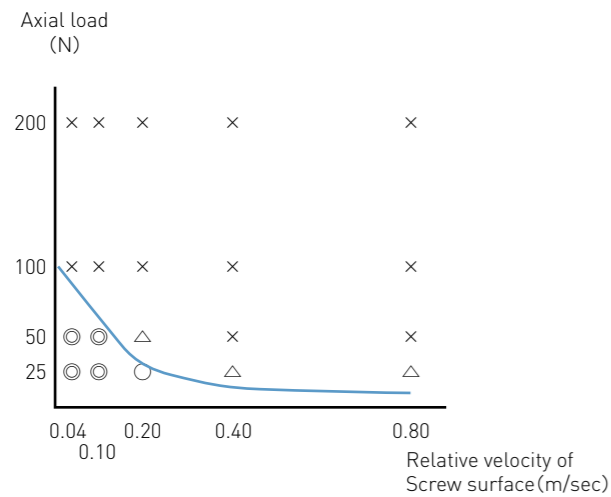

Model : MRH0805 / Lubricant : None

Evaluation :

- ◎ Stable operational conditions were maintained for the long term.
- Operation were good, but some wears were seen on the Nuts.
- △ Operations became difficult in a relatively short time.
- × Operations became difficult in the short time.

In case of $FV < 5 (N \cdot m/s)$, stable operations were maintained. Operations under $FV > 10 (N \cdot m/s)$, maintaining stability was difficult.

Axial Load should be treated more carefully as to upper limits rather than relative speed.

• Endurance test data of Preloaded products(BP2 type)

Model : $\phi 10$ mm、Lead = 6mm
 Load : None
 Speed : 1000rpm
 Travel : 400mm(2-way)
 Lubricant : None
 Result : After running 100km, operation were good
 Starting Torque monitor : see Diagram right

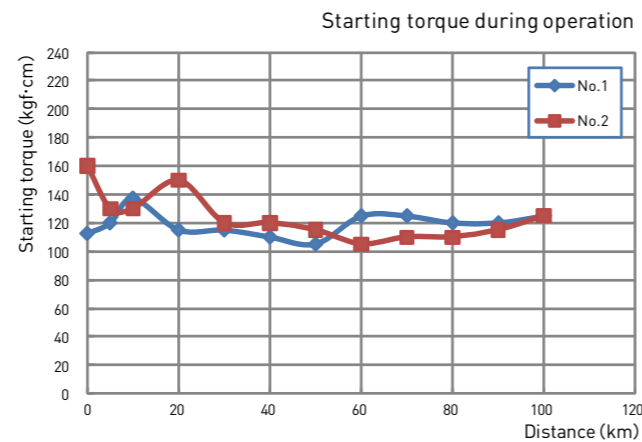

● **Special products**

Regarding KSS Resin Lead Screws, the standard material of Nut is MC nylon(MC703HL), but we also provide with the following Nut materials.

Please inquire KSS if Trapezoidal thread and ACME thread are needed.

In case of bulk order, it is possible to save the price to select material which is manufactured by injection molding.

Table D-12 : Product performance comparison

Product	MRH	MRS	MRE	MRZ
Classification	Standard	Customized		
Operating environment	Standard environment			Special environment
Nut appearance				
Material	Polyamide type			Polyether ether ketone type
Features	Balanced performance			Flame resistance, heat/water resistance
Other	Good sliding properties	—	Good electrical conductivity	Food hygiene, chemical resistance
Mechanical strength	○	○	○	◎
Heat resistance	○	○	○	◎
Wear resistance	◎	◎	◎	○
Chemical resistance	○	○	○	◎
Machinability	◎	◎	◎	○

- ◎ superior
- usable
- △ relatively inferior
- ▲ inferior

Fig. D-13 : Evaluation each material

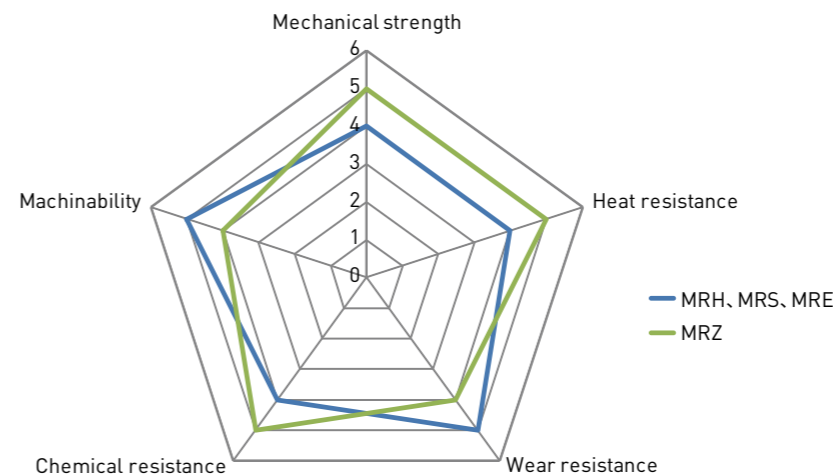

MRH-A,B series (Customized Products)

Dimension table

Model number notation



- ① Nut model
- ② Screw Shaft nominal diameter (mm)
- ③ Lead (mm)
- ④ Flange configuration
 - A : 2 holes Only products with $\phi 6$ mm
 - B : 4 holes
- ⑤ Screw thread length (mm)
- ⑥ Thread direction (Right-hand only)
- ⑦ Screw Shaft total length (mm)
- ⑧ Number of Nut
(Example : N2 means 2 Nuts on a Shaft. There is no notation when 1 Nut.)

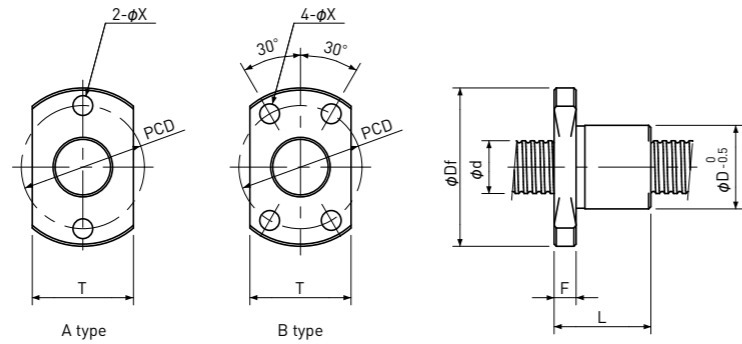

Unit:mm

Model	Screw Shaft				Nut								Standard Shaft length
	Dia. d	Lead	Root dia.	No. of threads	D	L	Df	F	P.C.D	X	Nut type	T	
MRH0602A	6	2	5.1	1	10	14	20	3	15	3.1	A	10	300
MRH0606A		6	5.2	2									
MRH0609A		9	5.3	4									
MRH0802B	8	2	6.6	1	13	16	26	4	20	3.6	B	17	400
MRH0805B		5	6.6	2									
MRH0808B		8	6.7	2									
MRH0812B		12	6.7	4									
MRH1002B	10	2	8.6	1	15	20	28	4	22	3.6	B	19	500
MRH1006B		6	8.4	2									
MRH1010B		10	8.4	2									
MRH1015B		15	8.4	4									
MRH1020B		20	8.7	4									
MRH1202B	12	2	10.6	1	18	24	31	5	25	4.8	B	20	600
MRH1206B		6	10.4	2									
MRH1210B		10	10.4	2									
MRH1220B		20	10.4	6									
MRH1230B		30	10.4	8									

- Note 1) Additional machining of Screw Shafts should be performed by KSS. Note that accuracy cannot be guaranteed if additional machining is performed by someone other than KSS.
- Note 2) When additional end-journal machining is performed by someone other than KSS, always remove the Nut from the Screw Shaft. After machining, wash away any debris on the Screw Shaft with clean refined kerosene or similar material.
- Note 3) The Shaft end diameter should be smaller than the Screw Shaft Root diameter, and the Screw thread length should be specified in 1mm unit.
- Note 4) Only Right-hand thread is available.
- Note 5) Screw Shafts and Nuts are not sold separately.

MRH-BP2 series (Customized Products)

Dimension table

Model number notation

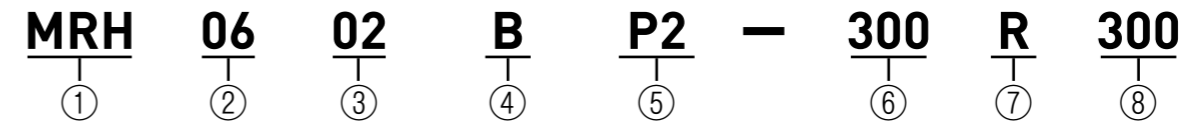

- ① Nut model
- ② Screw Shaft nominal diameter (mm)
- ③ Lead (mm)
- ④ Flange configuration
 - B : 2 flat faces (4 holes)
- ⑤ Backlash free mark
 - P2 : Standard Preload
- ⑥ Screw thread length (mm)
- ⑦ Thread direction (Right-hand only)
- ⑧ Screw Shaft total length (mm)

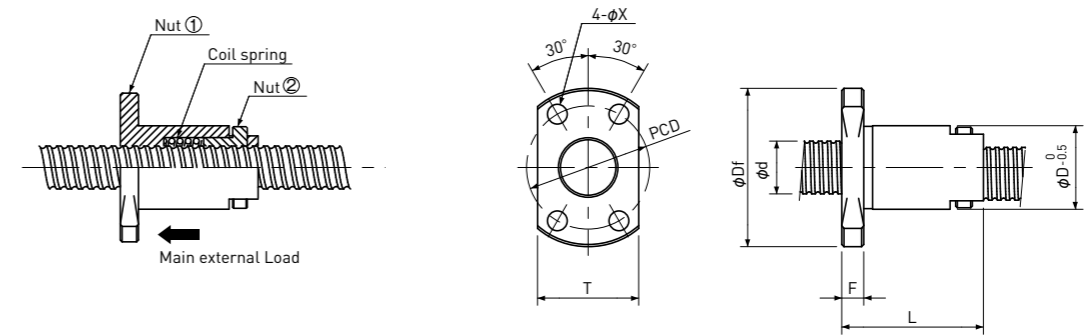

Unit:mm

Model	Screw Shaft				Nut								Standard Shaft length
	Dia. d	Lead	Root dia.	No. of threads	D	L	Df	F	P.C.D	X	T		
MRH0602BP2	6	2	5.1	1	13	20	26	4	20	3.6	17	300	
MRH0606BP2		6	5.2	2									
MRH0609BP2		9	5.3	4									
MRH0802BP2	8	2	6.6	1	15	23	28	4	22	3.6	19	400	
MRH0805BP2		5	6.6	2									
MRH0808BP2		8	6.7	2									
MRH0812BP2		12	6.7	4									
MRH1002BP2	10	2	8.6	1	18	30	31	5	25	4.8	20	500	
MRH1006BP2		6	8.4	2									
MRH1010BP2		10	8.4	2									
MRH1015BP2		15	8.4	4									
MRH1020BP2		20	8.7	4									
MRH1202BP2	12	2	10.6	1	23	38	41	5	33	4.8	25	600	
MRH1206BP2		6	10.4	2									
MRH1210BP2		10	10.4	2									
MRH1220BP2		20	10.4	6									
MRH1230BP2		30	10.4	8									

- Note 1) Additional machining of Screw Shafts should be performed by KSS. Note that accuracy cannot be guaranteed if additional machining is performed by someone other than KSS.
- Note 2) The Shaft end diameter should be smaller than the Screw Shaft Root diameter, and the Screw thread length should be specified in 1mm unit.
- Note 3) Only Right-hand thread is available.
- Note 4) Screw Shafts and Nuts are not sold separately.
- Note 5) Please inquire regarding spring tension (lower or higher than standard is available).
- Note 6) It is recommended that the main external load is in the direction as indicated by the arrow in the Figure above.

●Caution

- 1) Lubrication
 - MC Nylon which is standard Nut material of MRH series includes oil, but depending on operating condition, abnormal noise or wearing at early stage might occur. In that case, surface treatment on shaft or grease applying are recommended.
- 2) Additional end-journal machining
 - Additional machining of Screw Shaft should be performed by KSS. Note that accuracy cannot be guaranteed if additional end-journal machining is performed by someone other than KSS.
 - Remove the Nut from the Screw Shaft for additional machining.
After machining, wash away any debris on the Screw Shaft with clean refined kerosene or similar material. For Backlash free type, it is difficult to reproduce Preload if Nut is removed. We will do additional machining when needed.
- 3) Handling and use precaution.
 - Do not subject to sudden impact, as this is a precision part.
 - Do not disassemble Backlash free type Nut.
 - When storing the products, please store in the original wrapping. Do not open the wrapping or tear the inner wrapping until ready to use. Dust may get inside the wrapper and may cause a decline in functionality.
 - If the products falls, loss of functionality due to damage to component parts may result. Please send products back to KSS so that we can check the products. There will be a charge for this service.
 - This product has been designed for normal use in temperatures under 80°C. In case of exceeding 80°C, please ask KSS.
 - Resin Lead Screws are mechanical components that generates thrust toward the axis. It is not constructed to accept Radial Load (Radial direction). This may result in wear and damage at an early stage. Therefore, there should be no Radial Load on the Resin Nut parts, take care to set up with other linear equipment for Radial Load.
 - Coarse mounting accuracy such as misalignment of Nut bracket and Support Bearing, perpendicularity of Nut mounting face, will affect Resin Lead Screws performance, so be careful with the mounting accuracy.



R-MSS (Y) Series

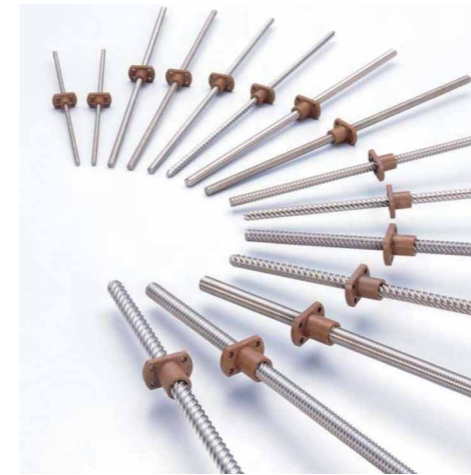

●BEAREE product is NTN registered trademark.

●Features

BEAREE AS5000 (PPS Resin: Poly Phenylene Sulfide) Nuts and Stainless (SUS304) Shafts are employed. This Lead Screw with low operating noise is able to be used as wide use.

- Wide use: Because Screw surfaces are smooth and its lead is high, the back drive operation can be easy.
- Low operation noise compared with Ball Screws.
- Due to the Nuts with low friction, the Screw efficiency is high.

●Specifications

Type	Single Nut with Flange
Nut material	BEAREE AS5000
Shaft material	JIS : SUS304
Axial play	50 μm or less (lead 1mm, 2mm) 100 μm or less (more than lead 2mm)
Accuracy grade	Ct10 (JISB1192-3)
Cumulative lead error	±0.21/300mm

●Material characteristics

	AS5000
Specific gravity	1.53
Hardness	80 Durometer
Tensile strength	51Mpa
Elongation	3%
Bending strength	61Mpa
Water absorption rate	0.05%
Linear Expansion coefficient	8.1 x 10 ⁻⁵ / °C
Maximum temperature	230°C

● Dimension table

Model number notation

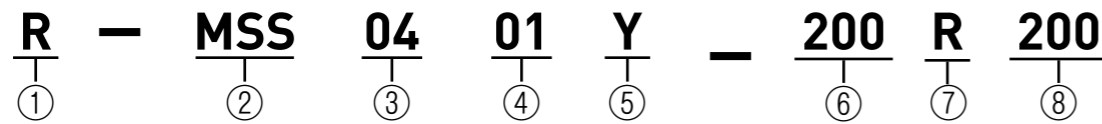

- ① NTN products
- ② Miniature Plastic Lead Screws
- ③ Shaft nominal diameter(mm)
- ④ Lead(mm)
- ⑤ Nut symbol : BEAREE AS5000
- ⑥ Screw thread length(mm)
- ⑦ Thread direction (Right-hand only)
- ⑧ Screw total length (mm)

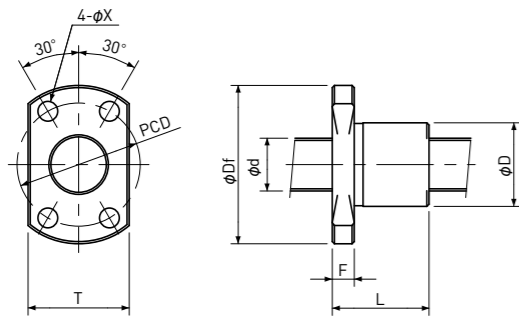

Unit:mm

Model	Shaft			Nut							Shaft length
	Dia. d	Lead	Number of thread	D	L	Df	F	P.C.D	X	T	
R-MSS0401Y	4	1	1	10	11.5	23	3.5	15	2.9	15	200
R-MSS0402Y		2	2								
R-MSS0601Y	6	1	1	12	14.5	26	4	18	3.4	17	300
R-MSS0602Y		2									
R-MSS0609Y		9									
R-MSS0618Y		18									
R-MSS0801Y	8	1	1	14	18	29	4	21	3.4	18	300
R-MSS0802Y		2									
R-MSS0812Y		12	4								
R-MSS0824Y		24	6								
R-MSS1002Y	10	2	1	16	22	33	5	24	4.5	21	300
R-MSS1015Y		15	4								
R-MSS1030Y		30	6								
R-MSS1202Y	12	2	1	18	25	35	5	26	4.5	22	300
R-MSS1218Y		18	6								
R-MSS1236Y		36	6								

Note 1) End-journal is not machined. Please inquire, if end-journal machining is required.

● Technical data

Model	Shaft		Permissible Axial Load N	Permissible Revolution rpm	Tightening Torque(max) N·mm	Efficiency %
	Dia. mm	Lead mm				
R-MSS0401Y	4	1	50	2000	180	45
R-MSS0402Y		2	60			70
R-MSS0601Y	6	1	120	2000	400	40
R-MSS0602Y		2	60			55
R-MSS0609Y		9	90			85
R-MSS0618Y		18	110			85
R-MSS0801Y	8	1	200	2000	400	30
R-MSS0802Y		2	290			45
R-MSS0812Y		12	210			80
R-MSS0824Y		24	210			85
R-MSS1002Y	10	2	460	1500	500	40
R-MSS1015Y		15	410			80
R-MSS1030Y		30	440			85
R-MSS1202Y	12	2	660	1000	500	35
R-MSS1218Y		18	750			75
R-MSS1236Y		36	540			80

Criteria : MSS0824Y, verification of no remarkable wear after 200km running test under 100N of Axial Load and 2,000rpm of Speed. Other than that are obtained by calculation.

① Efficiency η is calculated by following formula based on measurement results of rotational torque(M) under the Axial Load (Q).

$$\eta = \frac{R \cdot Q \cdot \tan \beta}{M} \times 100 (\%) \quad \tan \beta = \frac{\text{Lead}}{2\pi R}$$

η : Efficiency
 R : Pitch circle radius
 Q : Axial Load
 β : Lead angle
 M : Rotational torque

② Permissible Axial Load and Permissible Revolution are based on the test results under the following condition.

- 1) Test machine : NTN Lead Screw Durability test machine
- 2) Condition : Room temperature, no lubricant, 100mm travel (200mm/ cycle) or 200mm travel (400mm/cycle)
- 3) Criteria : No remarkable damage or wear on Screw surface after running test of 10^3 or 6×10^3 cycles under the Permissible Load and Revolution in the table above.

③ This number means when Plastic Nut is fixed onto the Bracket.