

SG1402

Shaft dia. $\phi 14$ Lead 2mm

C3&C5

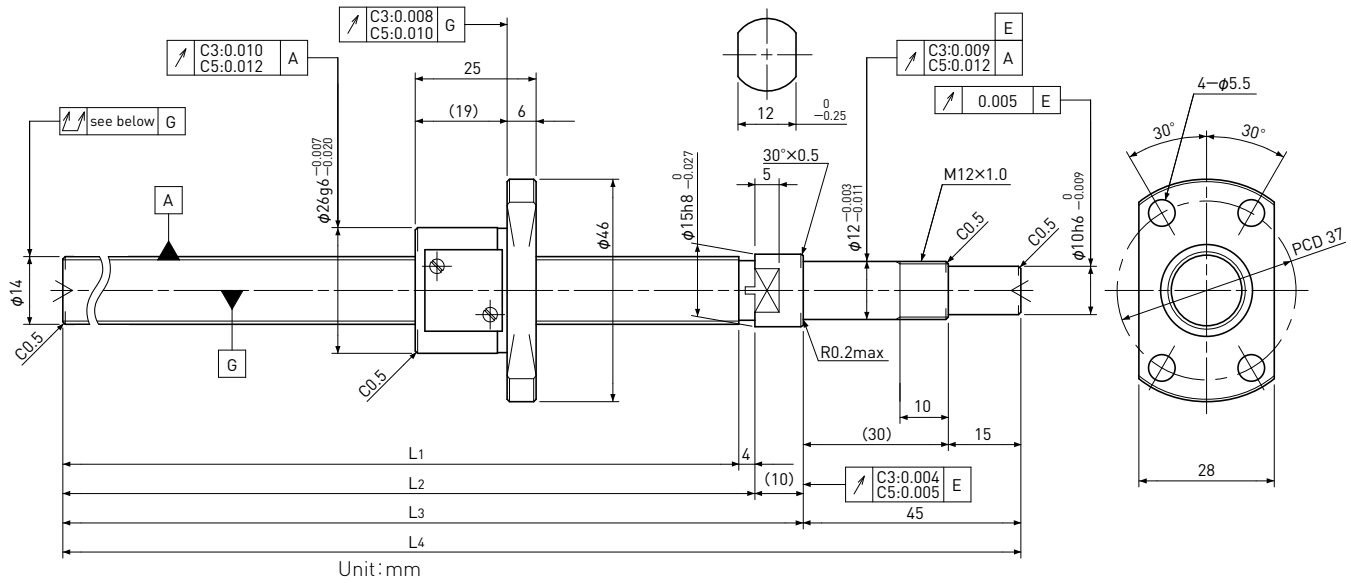

Unit: mm

Ball Screw Specifications	
Ball size	$\phi 1.5875$
Number of thread	1
Thread direction	Right
Shaft root dia.	$\phi 12.6$
Number of circuit	3.7×1
Shaft, Nut material	SCM415H
Surface hardness	HRC58~62 (Thread area)
Anti-rust treatment	Anti-rust oil

Supported-side end-journal profile

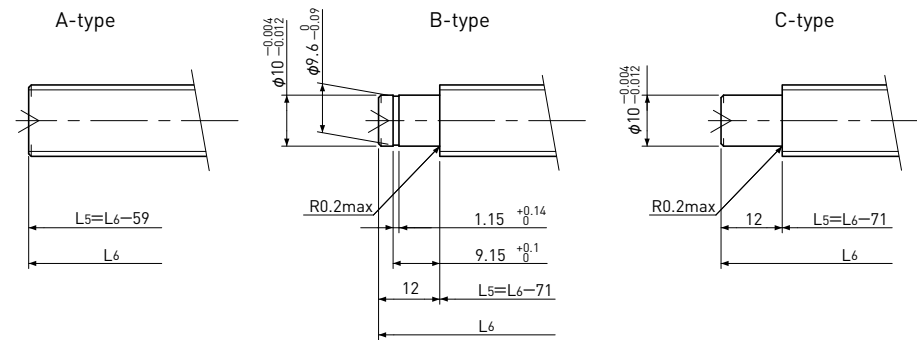

L5: Thread length after end-journal machining.
L6: Total length after end-journal machining.

Support-unit Recommendation	Supported-side	Fixed-side
	—	—

D-type : Other than the above.

Unit: mm

Ball Screw Model	Travel	Grade	Shaft length				Lead accuracy		Total Run-out	Axial play	Preload Torque Nm	Basic Load Rating N	
			L1	L2	L3	L4	Travel deviation e_p	Variation V_u				Dynamic C_a	Static C_{oa}
SG1402-141R200C3	115	C3	141	145	155	200	± 0.010	0.008	0.025	0 Spacer Ball (1:1)	0.010~ 0.050	2000	3800
SG1402-191R250C3	165	C3	191	195	205	250	± 0.010	0.008	0.030				
SG1402-241R300C3	215	C3	241	245	255	300	± 0.012	0.008	0.030				
SG1402-291R350C3	265	C3	291	295	305	350	± 0.012	0.008	0.040				
SG1402-391R450C3	365	C3	391	395	405	450	± 0.013	0.010	0.050	~0.005	—	3200	7500
SG1402-141R200C5	115	C5	141	145	155	200	± 0.020	0.018	0.040				
SG1402-191R250C5	165	C5	191	195	205	250	± 0.020	0.018	0.045				
SG1402-241R300C5	215	C5	241	245	255	300	± 0.023	0.018	0.045				
SG1402-291R350C5	265	C5	291	295	305	350	± 0.023	0.018	0.055				
SG1402-391R450C5	365	C5	391	395	405	450	± 0.025	0.020	0.060				

Note) Please refer to page A206 for order code of end-journal machining.