

SR0802

Shaft dia. $\phi 8$ Lead 2mm

Ct7&Ct10

* Please refer to p-A283 for stainless steel type.

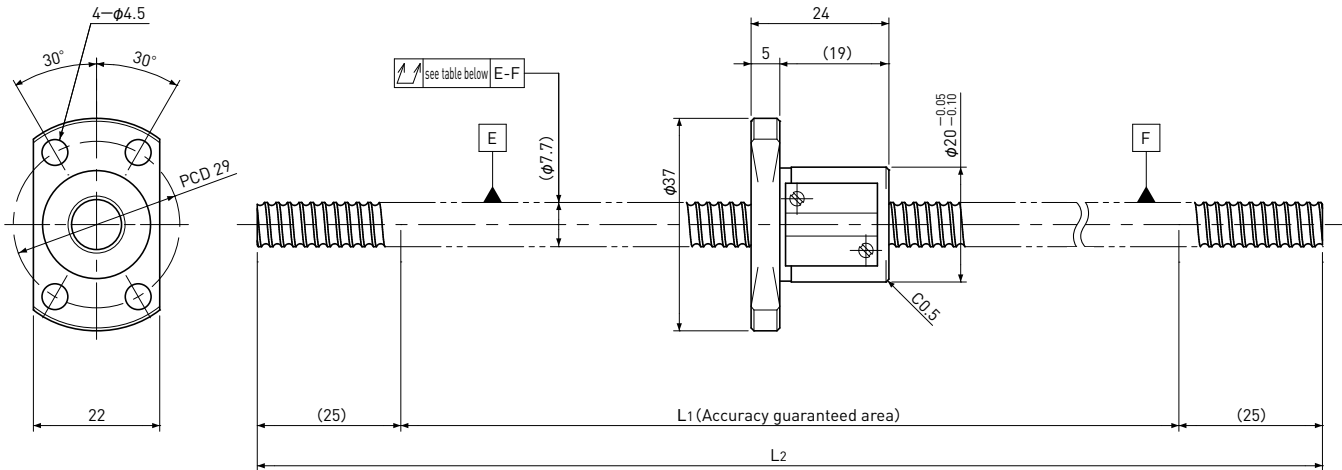

Unit: mm

Ball Screw Specifications	
Ball size	$\phi 1.5875$
Number of thread	1
Thread direction	Right
Shaft root dia.	$\phi 6.6$
Number of circuit	3.7×1
Shaft, Nut material	SCM415H
Surface hardness	HRC58~62 (Thread area)
Anti-rust treatment	Anti-rust oil

Unit: mm

Ball Screw Model	Travel	Grade	Shaft length		Lead accuracy		Total Run-out	Axial play	Preload Torque Nm	Basic Load Rating N	
			L1	L2	Travel deviation e_p	Variation V_{300}				Dynamic C_a	Static C_{oa}
SR0802-400R400C7	325	Ct7	350	400	± 0.06	0.05	0.120	~ 0.020	—	2400	4100
SR0802-400R400C10	325	Ct10	350	400	± 0.24	0.21	0.240	~ 0.050			

Note) Please designate end-journal profile with your sketch.