

SR1015

Shaft dia. $\phi 10$ Lead 15mm

Ct7&Ct10

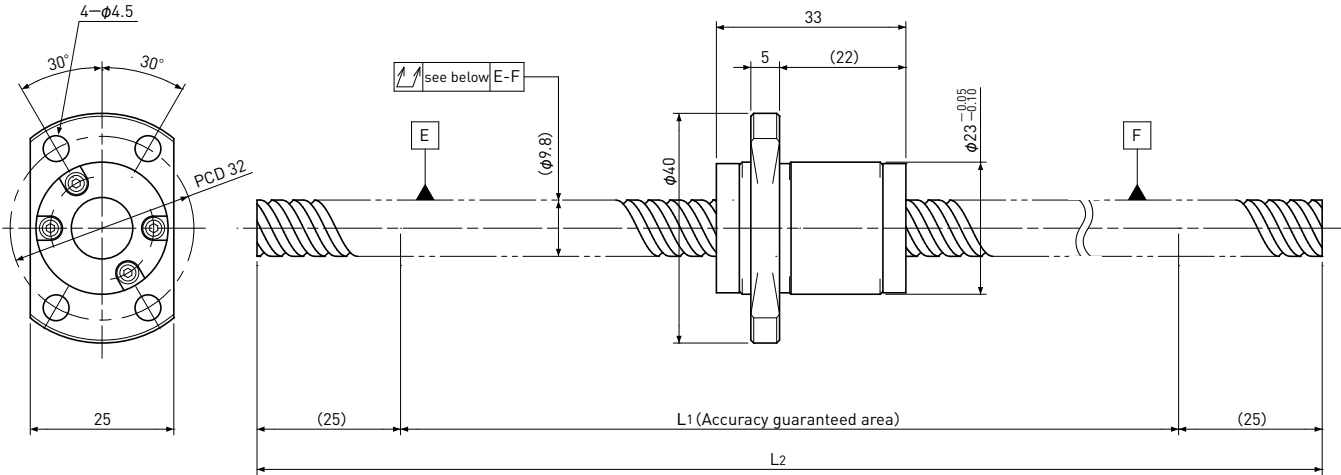

Unit: mm

Ball Screw Specifications	
Ball size	$\phi 2.0$
Number of thread	2
Thread direction	Right
Shaft root dia.	$\phi 8.4$
Number of circuit	1.6×2
Shaft, Nut material	SCM415H
Surface hardness	HRC58~62 (Thread area)
Anti-rust treatment	Anti-rust oil

Unit: mm

Ball Screw Model	Travel	Grade	Shaft length		Lead accuracy		Total Run-out	Axial play	Preload Torque Nm	Basic Load Rating N	
			L1	L2	Travel deviation e_p	Variation V_{300}				Dynamic C_a	Static C_{0a}
SR1015-450R450C7	365	Ct7	400	450	± 0.06	0.05	0.120	~0.020	—	3300	6400
SR1015-450R450C10	365	Ct10	400	450	± 0.28	0.21	0.240	~0.050			

Note) Please designate end-journal profile with your sketch.