

PSRT0401 | Shaft dia. $\phi 4$ Lead 1mm

C5

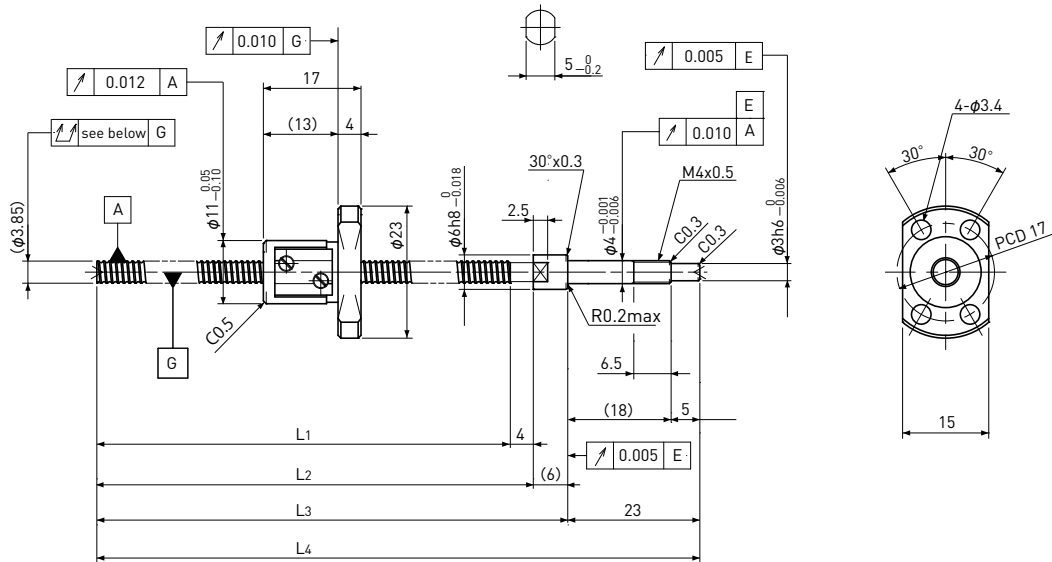

Unit: mm

Ball Screw Specifications	
Ball size	$\phi 0.8$
Number of thread	1
Thread direction	Right
Shaft root dia.	$\phi 3.3$
Number of circuit	3.7×1
Material	Shaft S55C+SUS303
	Nut SCM415H
Surface hardness	HRC58~ (Thread area)
Lubrication	KSS Original Grease MSG No.2

Supported-side end-journal profile

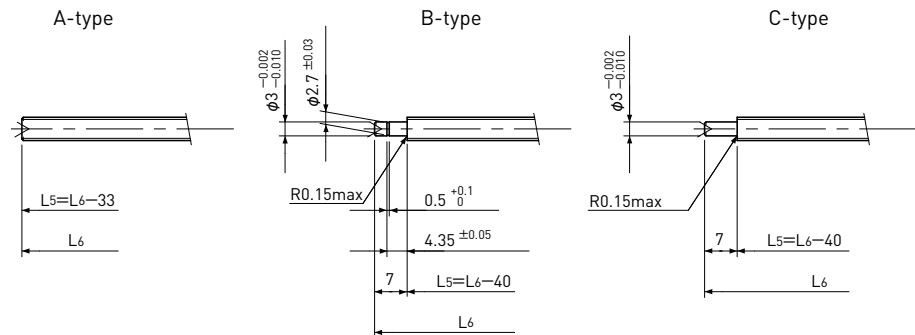

L5: Thread length after end-journal machining.
L6: Total length after end-journal machining.

Support-unit Recommendation	Supported-side	Fixed-side
	MSU-4CS/4GS	MSU-4C/4G

D-type : Other than the above.

Unit: mm

Ball Screw Model	Travel	Shaft length				Travel deviation e_p	Total Run-out \nearrow	Axial play	Basic Load Rating N	
		L1	L2	L3	L4				Dynamic Ca	Static Coa
PSRT0401-72R105C5	50	72	76	82	105	± 0.018	0.035	~ 0.005	560	790

Note) Please refer to page A321 for order code of end-journal machining.