

PSRT0601K

Compact Nut

Shaft dia. $\phi 6$ Lead 1mm

C5

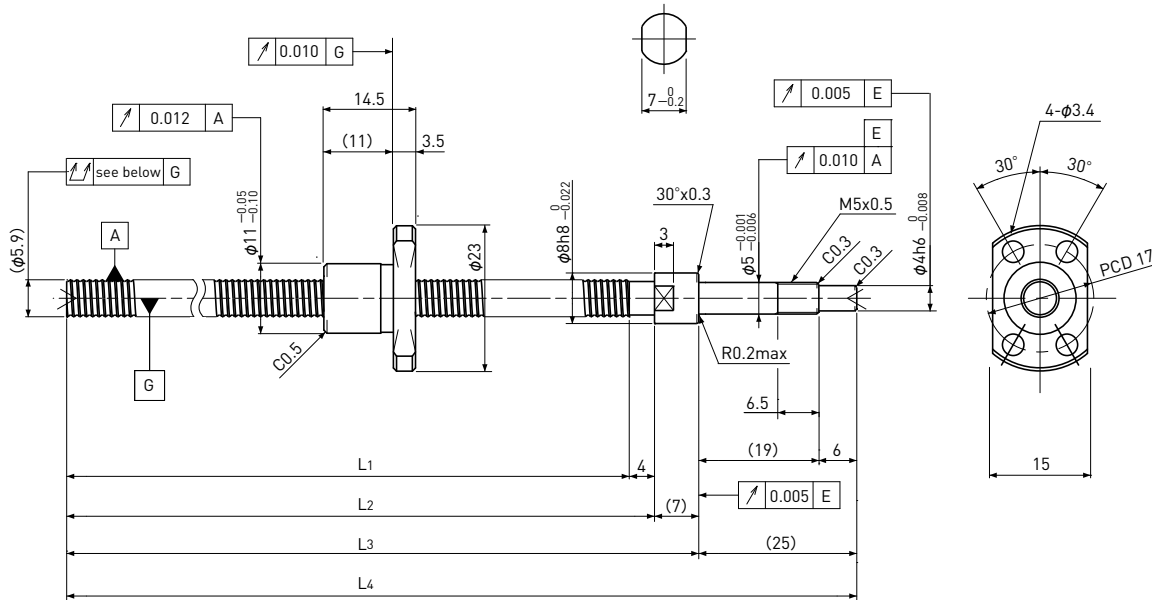

Unit: mm

Ball Screw Specifications		
Ball size		$\phi 0.8$
Number of thread		1
Thread direction		Right
Shaft root dia.		$\phi 5.3$
Number of circuit		1×3
Material	Shaft	S55C+SUS303
	Nut	SCM415H
Surface hardness		HRC58~ (Thread area)
Lubrication		KSS Original Grease MSG No.2

Supported-side end-journal profile

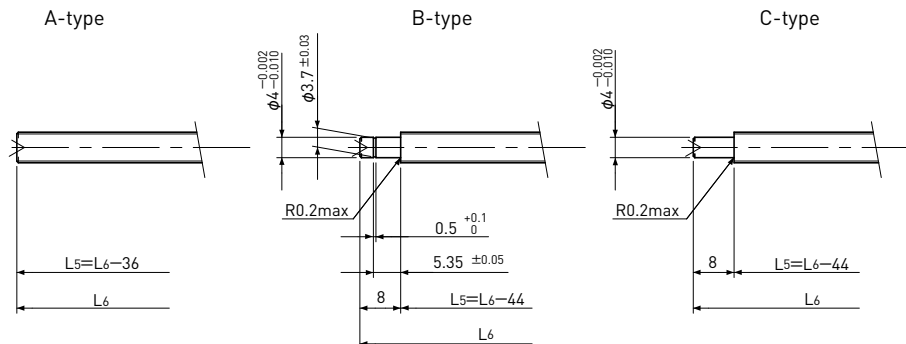

L5: Thread length after end-journal machining.
L6: Total length after end-journal machining.

Support-unit Recommendation	Supported-side	Fixed-side
	MSU-5CS/5GS	MSU-5C/5G

D-type : Other than the above.

Unit: mm

Ball Screw Model	Travel	Shaft length				Travel deviation e_p	Total Run-out	Axial play	Basic Load Rating N	
		L1	L2	L3	L4				Dynamic Ca	Static Coa
PSRT0601K-89R125C5	65	89	93	100	125	± 0.018	0.035	~ 0.005	560	950

Note) Please refer to page A321 for order code of end-journal machining.