

PSRT0801K Compact Nut

Shaft dia. $\phi 8$ Lead 1mm

C5

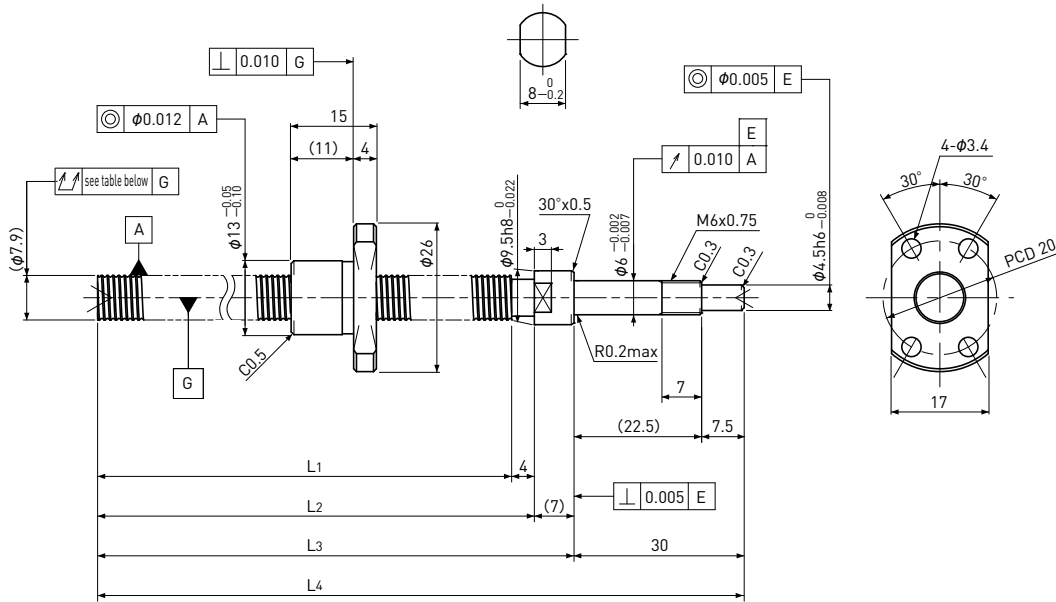

Unit: mm

Ball Screw Specifications		
Ball size	$\phi 0.8$	
Number of thread	1	
Thread direction	Right	
Shaft root dia.	$\phi 7.3$	
Number of circuit	1×3	
Material	Shaft	S55C+SUS303
	Nut	SCM415H
Surface hardness	HRC58~ (Thread area)	
Lubrication	KSS Original Grease MSG No.2	

Supported-side end-journal profile

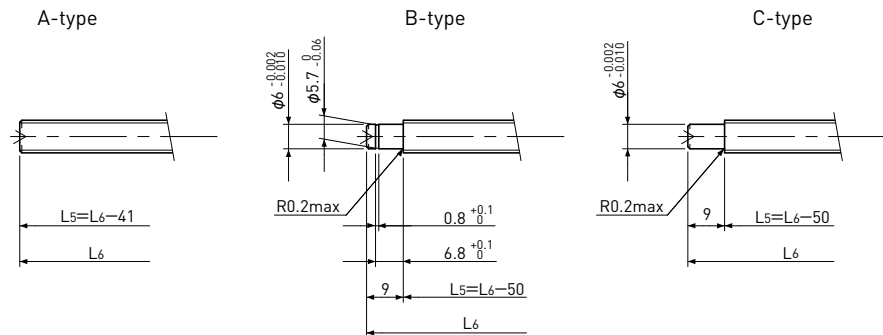

L5: Thread length after end-journal machining.
L6: Total length after end-journal machining.

Support-unit Recommendation	Supported-side	Fixed-side
	MSU-6CS/6GS, EF6	MSU-6C/6G, EK6

D-type : Other than the above.

Unit: mm

Ball Screw Model	Travel	Shaft length				Travel deviation e_p	Total Run-out	Axial play	Basic Load Rating N	
		L1	L2	L3	L4				Dynamic Ca	Static Coa
PSRT0801K-169R210C5	145	169	173	180	210	± 0.020	0.065	~ 0.005	650	1300

Note) Please refer to page A-321 for order code of end-journal machining.