

# PSRT0802

Shaft dia.  $\phi 8$  Lead 2mm

# C5

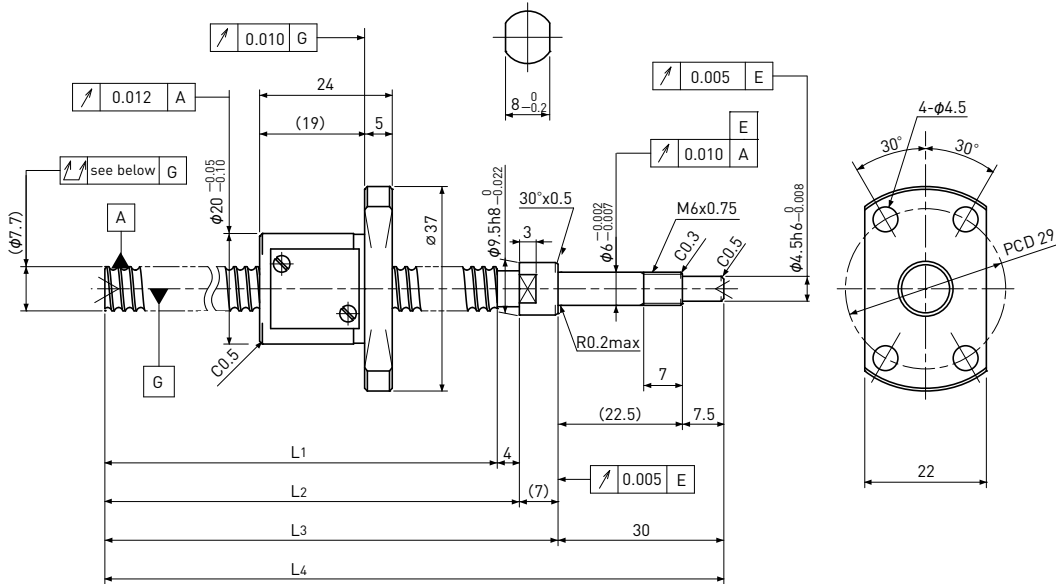

Unit: mm

Ball Screw Specifications		
Ball size	$\phi 1.5875$	
Number of thread	1	
Thread direction	Right	
Shaft root dia.	$\phi 6.6$	
Number of circuit	$3.7 \times 1$	
Material	Shaft	S55C+SUS303
	Nut	SCM415H
Surface hardness	HRC58~ (Thread area)	
Lubrication	KSS Original Grease MSG No.2	

### Supported-side end-journal profile

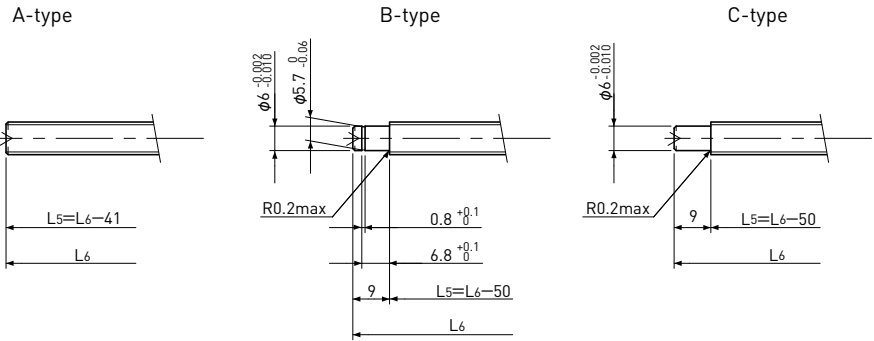

L5: Thread length after end-journal machining.  
L6: Total length after end-journal machining.

Support-unit Recommendation	Supported-side	Fixed-side
	MSU-6CS/6GS	MSU-6C/6G

D-type : Other than the above

Unit: mm

Ball Screw Model	Travel	Shaft length				Travel deviation $e_p$	Total Run-out	Axial play	Basic Load Rating N	
		L1	L2	L3	L4				Dynamic Ca	Static Coa
PSRT0802-169R210C5	140	169	173	180	210	$\pm 0.020$	0.065	$\sim 0.005$	2400	4100

Note) Please refer to page A321 for order code of end-journal machining.