

PSRT0812 | Shaft dia. $\phi 8$ Lead 12mm

C5

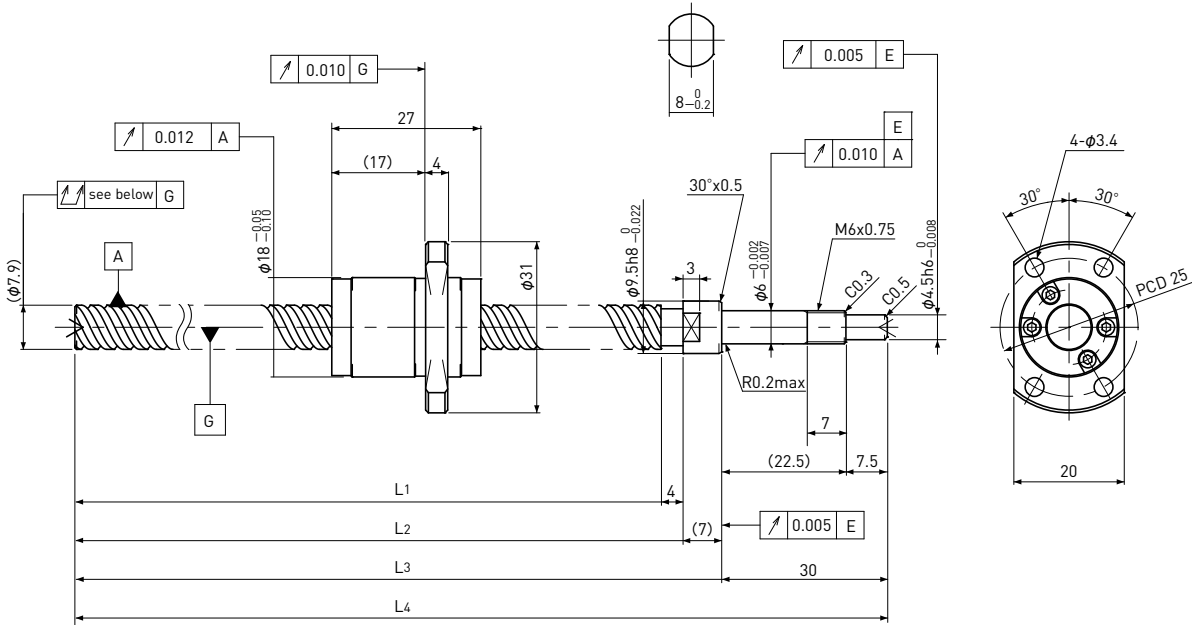

Unit: mm

Ball Screw Specifications		
Ball size		$\phi 1.5875$
Number of thread		2
Thread direction		Right
Shaft root dia.		$\phi 6.7$
Number of circuit		1.6 × 2
Material	Shaft	S55C+SUS303
	Nut	SCM415H
Surface hardness		HRC58~ (Thread area)
Lubrication		KSS Original Grease MSG No.2

Supported-side end-journal profile

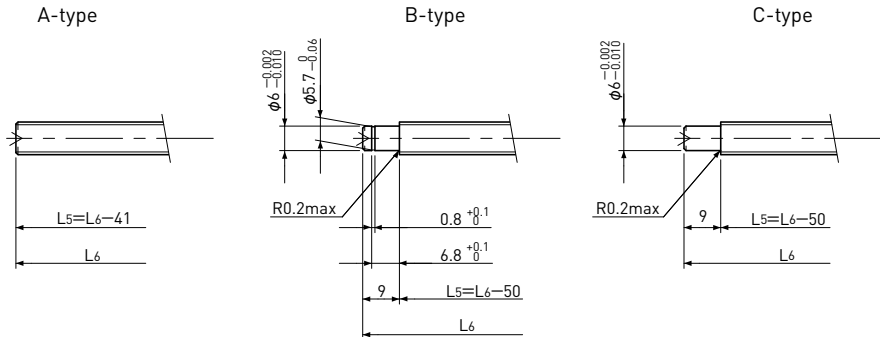

L5: Thread length after end-journal machining.
L6: Total length after end-journal machining.

Support-unit Recommendation	Supported-side	Fixed-side
	MSU-6CS/6GS	MSU-6C/6G

D-type : Other than the above.

Unit: mm

Ball Screw Model	Travel	Shaft length				Travel deviation e_p	Total Run-out $\uparrow\downarrow$	Axial play	Basic Load Rating N	
		L ₁	L ₂	L ₃	L ₄				Dynamic Ca	Static Coa
PSRT0812-169R210C5	135	169	173	180	210	± 0.020	0.065	~ 0.005	2200	4000

Note) Please refer to page A321 for order code of end-journal machining.