

## Precision Ball Screws

## Single Nut with Flange

## Backlash type/Preload type

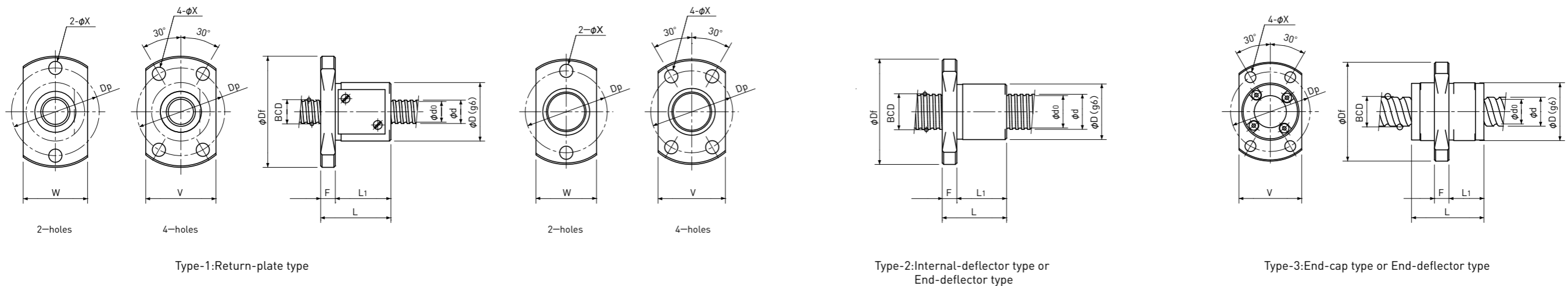

Unit : mm

Ball Nut Model number	Shaft nominal dia. d	Lead	Ball size	BCD	Lead angle	Root dia. d <sub>0</sub>	Number of Circuit	Basic Load Rating N		Nut Rigidity N/μm	Nut dimension										Ball Nut Model number
								Dynamic Ca	Static Coa		Nut type	D	Df	L	L <sub>1</sub>	F	W	V	Dp	Bolt Hole X	
FBS 1003 B	10	3	2.0	10.30	5° 18'	8.2	3.7×1	3900 / 2500	7200 / 3600	140 / 118	1	24	44	30	24	6	26	27	35	5.5	FBS 1003 B
FBS 1004 A	10	4	2.0	10.30	7° 03'	8.2	2.7×1	3000 / 1800	5200 / 2600	104 / 86	1	24	44	29	23	6	26	27	35	5.5	FBS 1004 A
FDB 1005 A	10	5	2.0	10.30	8° 47'	8.2	2.7×1	3000 / -	5200 / -	103 / -	2	23	40	26	21	5	-	25	32	4.5	FDB 1005 A
FBS 1005 A	10	5	2.0	10.30	8° 47'	8.2	2.7×1	3000 / 1800	5200 / 2600	103 / 85	1	24	44	34	28	6	26	27	35	5.5	FBS 1005 A
FEB 1010 A	10	10	2.0	10.50	16° 52'	8.4	1.6×2	3300 / -	5900 / -	117 / -	3	23	40	24	13	5	-	25	32	4.5	FEB 1010 A
FEB 1015 A	10	15	2.0	10.50	24° 27'	8.4	1.6×2	3300 / -	6400 / -	110 / -	3	23	40	33	22	5	-	25	32	4.5	FEB 1015 A
FEB 1020 A	10	20	1.5875	10.40	31° 28'	8.7	0.7×4	2100 / -	4000 / -	88 / -	3	20	37	23	13	5	-	22	29	4.5	FEB 1020 A
FEB 1030 A	10	30	1.5875	10.40	42° 33'	8.7	0.7×4	2100 / -	4000 / -	76 / -	3	20	37	31.5	21.7	5	-	22	29	4.5	FEB 1030 A

Note 1) The diameter of one of the Screw Shaft ends must be less than the Screw Shaft Root diameter, otherwise Ball Nut cannot be installed.

Note 2) Ball Nut dimension is without seal at the both ends.

If the seals are required, Ball Nut dimension should be changed, in that case, please ask KSS. Some type of Ball Nuts cannot equip with seals, please ask KSS representative.

Note 3) The Rigidity values shown in the table are theoretical values of Ball Nut Rigidity calculated from the amount of Elastic Displacement under the following conditions.  
Backlash type ; Apply the Axial load equivalent to 30% of the Basic Dynamic Load Rating Ca.  
Preload type ; Apply the Preload equivalent to 5% of the Basic Dynamic Load Rating Ca.  
For Axial load or Preload condition other than the above, see the formula in p-A823, you can calculate Rigidity using this formula.

Note 4) All models are Right-hand Screw. If Left-hand Screw is required, please ask KSS representative.

Note 5) Basic Load Rating and Rigidity for Backlash type and Preload type are described in the same cell.

Basic Load Rating N		Nut Rigidity N/μm
Dynamic Ca	Static Coa	
1000 / 640	3300 / 1650	164 / 138
		Preload type
		Backlash type