

## Precision Ball Screws

## Single Nut with Flange

Backlash type/Preload type

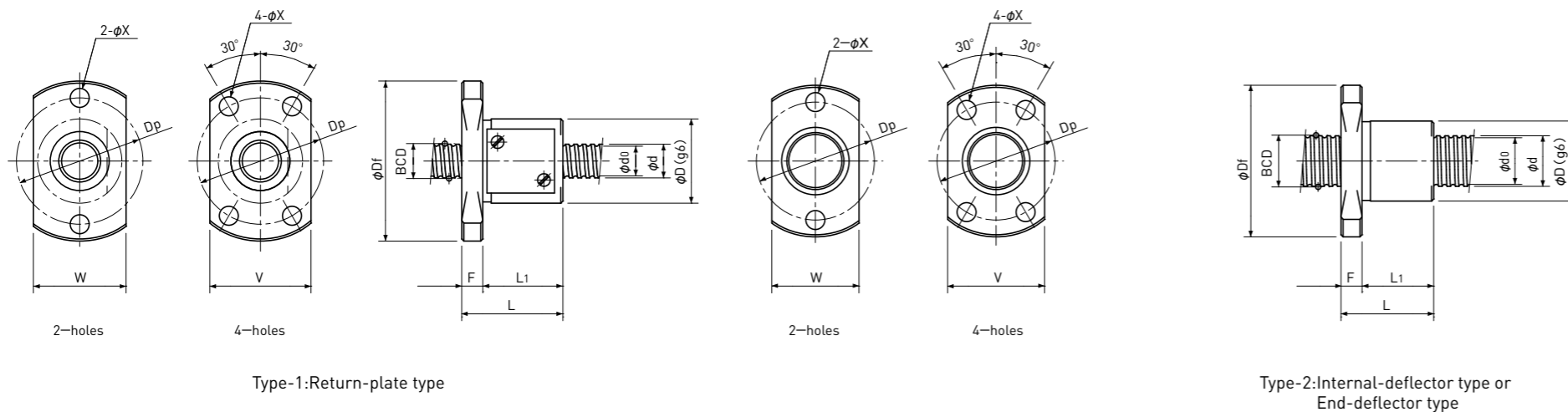

Unit: mm

Ball Nut Model number	Shaft nominal dia. d	Lead	Ball size	BCD	Lead angle	Root dia. d <sub>0</sub>	Number of Circuit	Basic Load Rating N		Nut Rigidity N/μm	Nut dimension										Ball Nut Model number
								Dynamic Ca	Static Coa		Nut type	D	Df	L	L <sub>1</sub>	F	W	V	Dp	Bolt Hole X	
FBS 1601 B	16	1	0.8	16.15	1°08'	15.3	3.7×1	1000 / 640	3300 / 1650	164 / 138	1	28	48	21	15	6	30	30	39	5.5	FBS 1601 B
FKB 1602 A	16	2	1.2	16.30	2°14'	15.0	1×3	1850 / 1850	5000 / 5000	137 / 213	2	24	43	20	14	6	26	27	34	5.5	FKB 1602 A
FBS 1602 B	16	2	1.5875	16.30	2°14'	14.6	3.7×1	3400 / 2100	8600 / 4300	197 / 163	1	28	48	25	19	6	30	30	39	5.5	FBS 1602 B
FKB 1603 A	16	3	2.0	16.50	3°19'	14.4	1×3	3600 / 3600	8000 / 8000	146 / 227	2	26	45	32	26	6	28	28	36	5.5	FKB 1603 A
FBS 1603 B	16	3	2.0	16.30	3°21'	14.2	3.7×1	4900 / 3100	11600 / 5800	205 / 172	1	32	53	30	24	6	34	34	44	5.5	FBS 1603 B
FKB 1604 A	16	4	2.381	16.65	4°22'	13.9	1×3	4800 / 4800	10000 / 10000	152 / 237	2	28	47	29	23	6	30	30	38	5.5	FKB 1604 A
FBS 1604 B	16	4	2.381	16.30	4°28'	13.8	3.7×1	6200 / 3900	13600 / 6800	209 / 174	1	34	54	34	28	6	36	36	45	5.5	FBS 1604 B
FBS 1605 B	16	5	3.175	16.50	5°31'	13.2	3.7×1	9100 / 5700	18200 / 9100	217 / 182	1	38	57	42	36	6	40	40	48	5.5	FBS 1605 B

Note 1) The diameter of one of the Screw Shaft ends must be less than the Screw Shaft Root diameter, otherwise Ball Nut cannot be installed.

Note 2) Ball Nut dimension is without seal at the both ends.

If the seals are required, Ball Nut dimension should be changed, in that case, please ask KSS. Some type of Ball Nuts cannot equip with seals, please ask KSS representative.

Note 3) The Rigidity values shown in the table are theoretical values of Ball Nut Rigidity calculated from the amount of Elastic Displacement under the following conditions.  
Backlash type ; Apply the Axial load equivalent to 30% of the Basic Dynamic Load Rating Ca.  
Preload type ; Apply the Preload equivalent to 5% of the Basic Dynamic Load Rating Ca.  
For Axial load or Preload condition other than the above, see the formula in p-A823, you can calculate Rigidity using this formula.

Note 4) All models are Right-hand Screw. If Left-hand Screw is required, please ask KSS representative.

Note 5) Basic Load Rating and Rigidity for Backlash type and Preload type are described in the same cell.

Basic Load Rating N		Nut Rigidity N/μm
Dynamic Ca	Static Coa	
1000 / 640	3300 / 1650	164 / 138
		Preload type
		Backlash type