

# Precision Ball Screws

## Bi-directional Nut with Flange

## Backlash type/Preload type

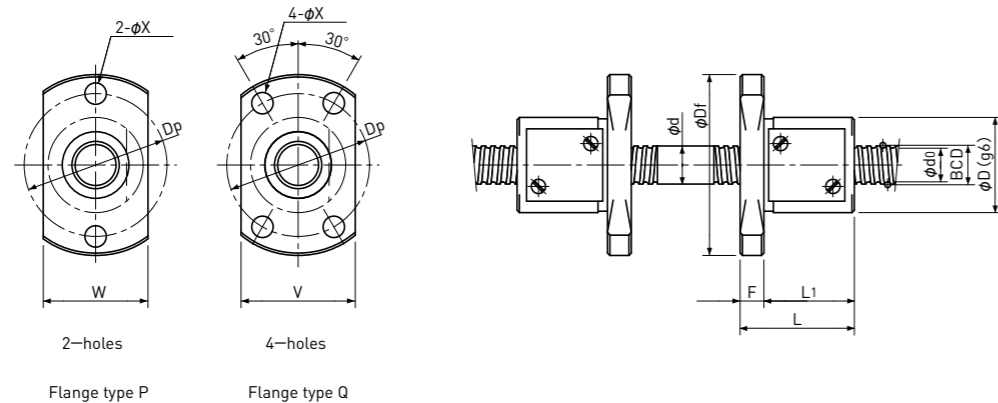

Type-1:Return-plate type

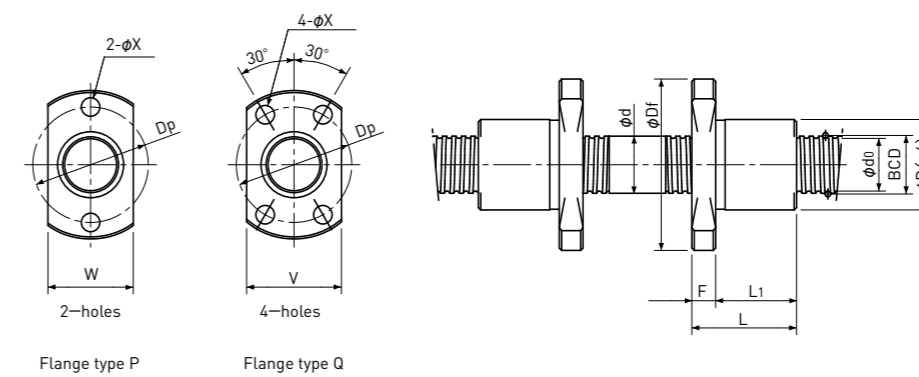

Type-2:Internal-deflector type

Unit:mm

Ball Nut Model number	Shaft nominal dia. d	Lead	Ball size	BCD	Lead angle	Root dia. d <sub>0</sub>	Number of Circuit	Basic Load Rating N		Nut Rigidity N/μm	Nut dimension										Ball Nut Model number	
								Dynamic Ca	Static Coa		Nut type	D	Df	L	L <sub>1</sub>	F	W	V	Dp	Bolt Hole X		Flange Type
FKB 1201 A	12	1	0.8	12.20	1°30'	11.3	1×3	780 / 780	2000 / 2000	97 / 152	2	17	34	16	11	5	19	21	26	4.5	P,Q	FKB 1201 A
FKB 1202 A	12	2	1.2	12.30	2°58'	11.0	1×3	1600 / 1600	3700 / 3700	109 / 169	2	19	36	19	14	5	21	23	28	4.5	P,Q	FKB 1202 A
FKB 1202.5 A	12	2.5	1.5875	12.40	3°41'	10.7	1×3	2300 / 2300	4700 / 4700	112 / 174	2	20	37	21	16	5	22	24	29	4.5	P,Q	FKB 1202.5 A
FKB 1203 A	12	3	2.0	12.50	4°22'	10.4	1×3	3100 / 3100	5700 / 5700	115 / 179	2	22	41	32	26	6	24	26	32	5.5	P,Q	FKB 1203 A
FBS 1204 B	12	4	2.381	12.30	5°55'	9.8	3.7×1	5400 / 3400	10200 / 5100	165 / 139	1	28	48	33	27	6	30	30	39	5.5	P,Q	FBS 1204 B
FBS 1401 B	14	1	0.8	14.15	1°17'	13.3	3.7×1	960 / 610	2900 / 1450	148 / 124	1	26	46	21	15	6	28	28	37	5.5	P,Q	FBS 1401 B
FKB 1402 A	14	2	1.2	14.30	2°33'	13.0	1×3	1700 / 1700	4300 / 4300	122 / 190	2	21	40	20	14	6	23	26	31	5.5	P,Q	FKB 1402 A
FKB 1402.5 A	14	2.5	1.5875	14.40	3°10'	12.7	1×3	2500 / 2500	5600 / 5600	127 / 197	2	22	41	22	16	6	24	26	32	5.5	P,Q	FKB 1402.5 A
FKB 1403 A	14	3	2.0	14.50	3°46'	12.4	1×3	3400 / 3400	6800 / 6800	131 / 204	2	24	43	32	26	6	26	27	34	5.5	P,Q	FKB 1403 A
FKB 1404 A	14	4	2.381	14.65	4°58'	11.9	1×3	4500 / 4500	8600 / 8600	136 / 212	2	26	45	29	23	6	28	28	36	5.5	P,Q	FKB 1404 A
FBS 1405 B	14	5	2.381	14.30	6°21'	11.8	3.7×1	5700 / 3600	11600 / 5800	186 / 157	1	30	51	39	33	6	32	32	42	5.5	P,Q	FBS 1405 B

- Note 1)The diameter of the Screw Shaft both ends must be less than the Screw Shaft Root diameter, otherwise Ball Nut cannot be installed.
- Note 2)Ball Nut dimension is without seal at the both ends.  
If the seals are required, Ball Nut dimension should be changed, in that case, please ask KSS.  
Some type of Ball Nuts cannot equip with seals, please ask KSS representative.
- Note 3)The Rigidity values shown in the table are theoretical values of Ball Nut Rigidity calculated from the amount of Elastic Displacement under the following conditions.  
Backlash type ; Apply the Axial load equivalent to 30% of the Basic Dynamic Load Rating Ca.  
Preload type ; Apply the Preload equivalent to 5% of the Basic Dynamic Load Rating Ca.  
For Axial load or Preload condition other than the above, see the formula in p-A823, you can calculate Rigidity using this formula.
- Note 4)Basic Load Rating and Rigidity for Backlash type and Preload type are described in the same cell.

Basic Load Rating N		Nut Rigidity N/μm
Dynamic Ca	Static Coa	
1000 / 640	3300 / 1650	164 / 138

Preload type  
Backlash type