

Rolled Ball Screw + 2-phase Stepping Motor

DMBR □35 / NEMA 14

Shaft dia. $\phi 8$

[DMBR0801 / DMBR0802 / DMBR0805]

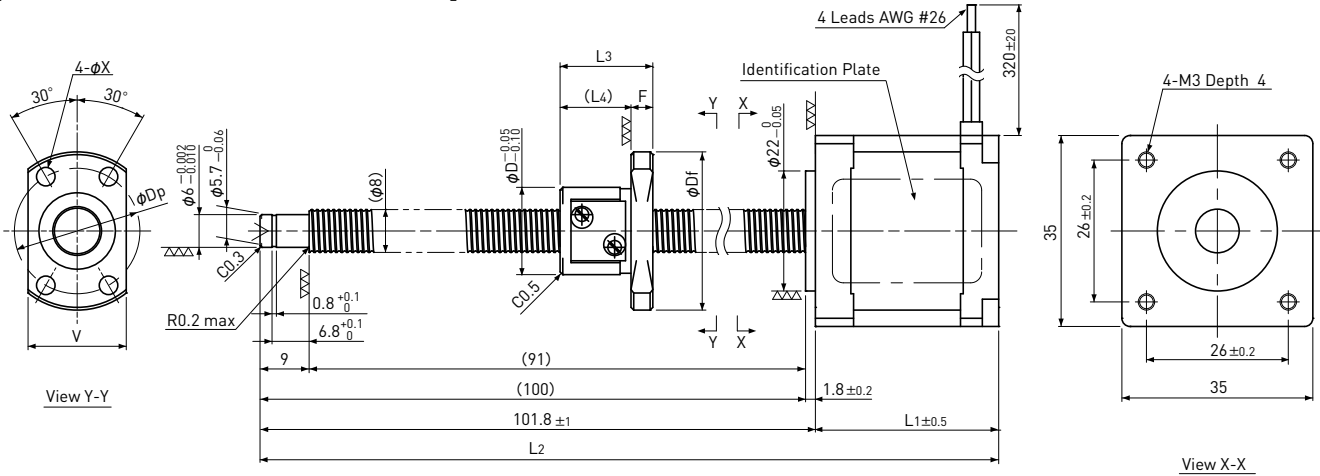

[DMBR0810]

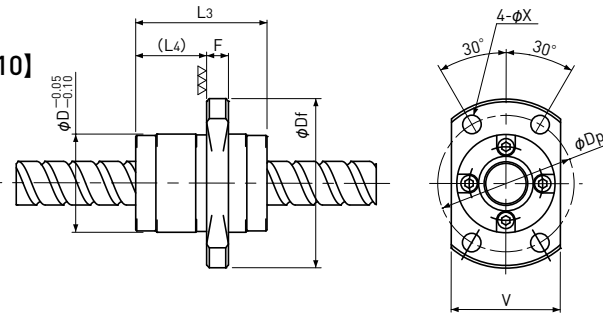

Motor Wire	
A	Red
Ā	Red/White
B	Green
B̄	Green/White

Unit:mm

Model	Lead	Travel	L ₁	L ₂	L ₃	L ₄	D	D _f	F	V	D _p	X	Mass (g)
DMBR0801-14E2110	1	58	33.6	135.4	17	13	16	29	4	18	23	3.4	212
DMBR0802-14E2110	2	50	33.6	135.4	24	19	20	37	5	22	29	4.5	240
DMBR0805-14E2110	5	47	33.6	135.4	28	24	18	31	4	20	25	3.4	234
DMBR0810-14E2110	10	54	33.6	135.4	24	13	18	31	4	20	25	3.4	226
DMBR0801-14E2215	1	58	45.6	147.4	17	13	16	29	4	18	23	3.4	292
DMBR0802-14E2215	2	50	45.6	147.4	24	19	20	37	5	22	29	4.5	320
DMBR0805-14E2215	5	47	45.6	147.4	28	24	18	31	4	20	25	3.4	314
DMBR0810-14E2215	10	54	45.6	147.4	24	13	18	31	4	20	25	3.4	304

Recommended Drivers	SD4030B3
---------------------	----------

Note) Refer to page P161 for connection diagram of recommended Drivers.

Ball Screw Specifications	
Accuracy grade	JIS Ct7
Thread direction	Right
Axial play	Max 0.03mm
Ball Screw material	Chrome-molybdenum steel
Surface hardness	Min. HRC58
Lubricant	KSS original grease MSG No.2

Motor Specifications		
Motor Model	14E2110	14E2215
Basic step angle	1.8°	
Driving method	2-phase Bi-polar	
Rated Voltage	DC 3.5 V	DC 4.0 V
Rated current	DC 1.0A/phase	DC 1.5A/phase
Winding resistance	3.5Ω	2.7Ω
Holding Torque	0.060Nm	0.10Nm
Rotor inertia	21.0g·cm ²	32.0g·cm ²
Operating temperature	-10°C~50°C	

Note) Please contact KSS if different journal profile or length from the above is required.