

Precision Ball Screw + 5-Phase Stepping Motor

MB 24 / NEMA 10

Shaft dia. $\phi 4$

Linear Actuator External type

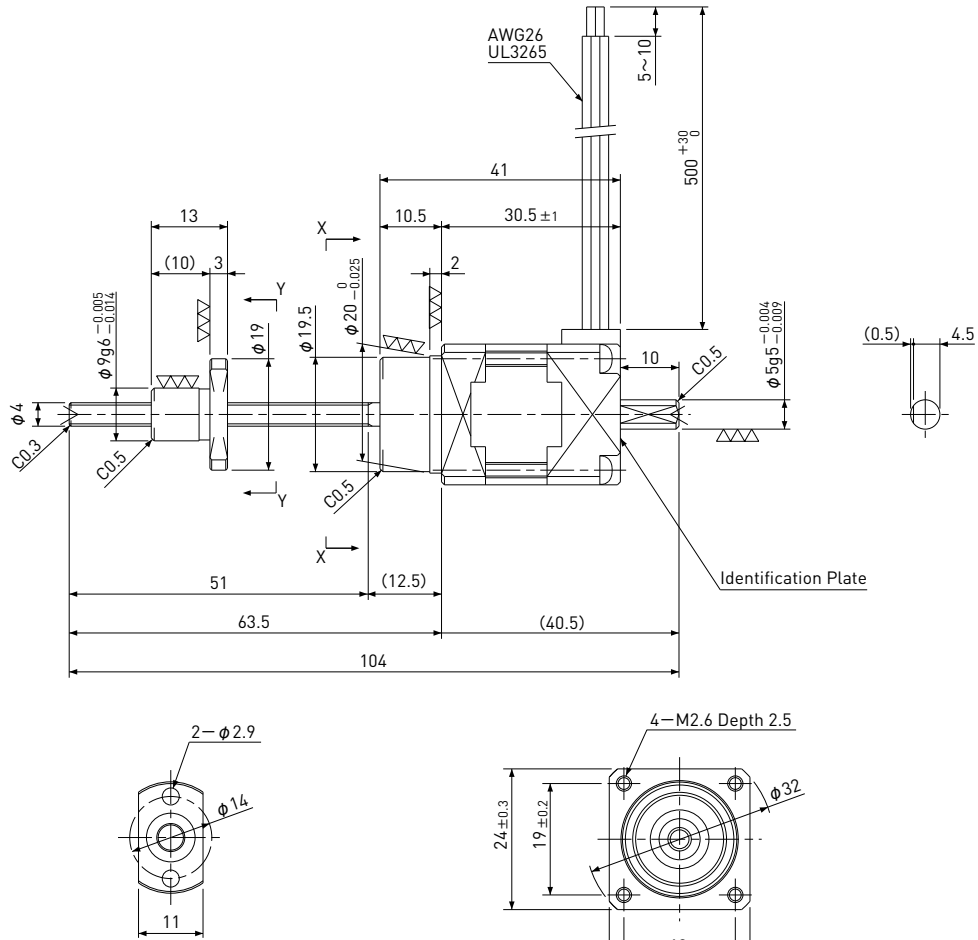

Unit:mm

Model	Lead	Travel	Reference Thrust	Mass
MB0401	1	30	50 (N)	100 (g)

Recommended Drivers	KR-A5CC
	KR-A55MC (Micro step)
	KR-A535M (Micro step / AC-100~220V)

Note) Refer to page P162 or P163 for connection diagram of recommended Drivers.

Ball Screw Specifications	
Accuracy grade	JIS C3
Thread direction	Right
Axial play	0mm
Shaft material	Stainless steel
Nut material	Chrome-molybdenum steel
Surface hardness	Min. HRC55 (Thread area)
Lubricant	KSS original grease MSG No.1

Motor Specifications	
Basic step angl	0.72°
Rated Voltage	DC 0.83 V
Rated current	DC 0.75 A/phase
Winding resistance	1.1Ω
Holding Torque	0.018Nm
Rotor inertia	4.2g · cm ²
Operating temperature	-20°C~50°C

Note) Only shaft end cutting is available. Other than that, it would be customized order.