

Flex Actuator

Motor-less type (Standard) Rolled Ball Screw type Actuator

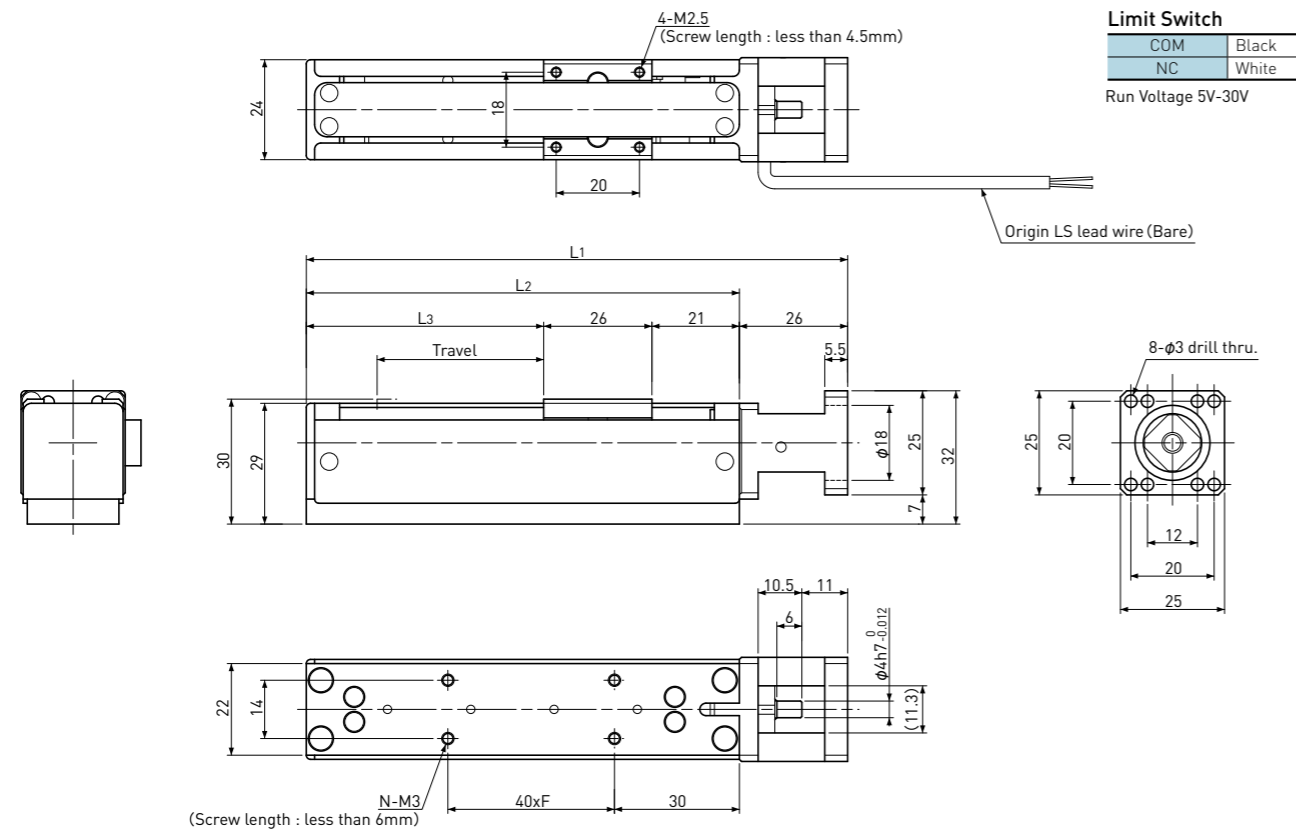

Note

- 1) There should be no condensation when using.
- 2) Permissible Moment is the number when no load in other direction.
- 3) Please consider Torque as reference number.
- 4) In case of Motor-less type, Repeatability & Lost motion are reference number.
- 5) In case of Motor-less type, Permissible speed & Load Capacity are recommended number.
- 6) Required Torque is under maximum vertical Load Capacity.
- 7) Recommended Coupling
 - SAKAI SEISAKUSYO : LAS-12C-4 × (3 or 4 or 5)
 - NBK : MWS-12C-4 × (4 or 5)
 - NBK : MOS-12C-4 × (3 or 4 or 5)
 - MISUMI : CPSCN12-4 × (4 or 5)

Model Number	Travel (mm)	Screw Lead (mm)	Motor Required Torque (Nm)	Length (mm)			F	N	Max. Load Capacity (N)		Permissible speed (mm / sec)	Mass (g)
				L1	L2	L3			Hor.	Vert.		
FAS-R010-020	20	1	0.009	110	84	37	1	4	29.4	19.6	0 ~ 25	160
FAS-R010-040	40	1	0.009	130	104	57	1	4	29.4	19.6	0 ~ 25	180
FAS-R020-040		2	0.011						29.4	19.6	0 ~ 50	
FAS-R060-040		6	0.017						19.6	9.8	0 ~ 150	
FAS-R100-040		10	0.015						19.6	4.9	0 ~ 250	
FAS-R010-080	80	1	0.009	170	144	97	2	6	29.4	19.6	0 ~ 25	225
FAS-R020-080		2	0.011						29.4	19.6	0 ~ 50	
FAS-R060-080		6	0.017						19.6	9.8	0 ~ 150	
FAS-R100-080		10	0.015						19.6	4.9	0 ~ 250	
FAS-R060-120	120	6	0.017	210	184	137	3	8	19.6	9.8	0 ~ 150	265
FAS-R100-120		10	0.015						19.6	4.9	0 ~ 250	
FAS-R060-160	160	6	0.017	250	224	177	4	10	19.6	9.8	0 ~ 150	310
FAS-R100-160		10	0.015						19.6	4.9	0 ~ 250	
FAS-R060-200	200	6	0.017	290	264	217	5	12	19.6	9.8	0 ~ 150	350
FAS-R100-200		10	0.015						19.6	4.9	0 ~ 250	

Please refer to Technical Description page S106 for the Datum clamp face of the Actuator.

Common Specifications	
Repeatability	Max. ±0.01mm
Lost Motion	Max. 0.01mm
Body Material	Aluminum
Sliding guide	Slide Guide rail
Sensor	Limit switch
Accuracy of Zero pt. return	Max. ±0.01mm
Permissible Moment	
Pitching Mp	0.10Nm
Yawing My	0.09Nm
Rolling Mr	0.23Nm
Lubrication	Grease MSG No.2(KSS)
Operating Temp.	0 ~ 40°C