

Rolled Ball Screws

Sleeve type Single Nut

Backlash type

- Rolled Ball Screws with integrated journal are available ($\phi 12$ or less only), which have larger diameter than threaded area shown below.

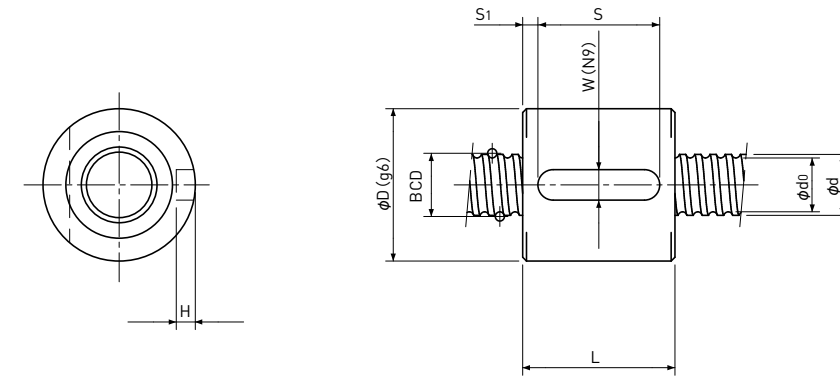
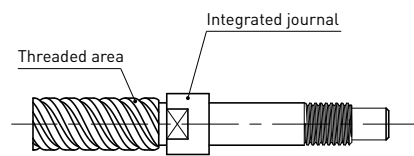

Unit:mm

Ball Nut Model number	Shaft nominal dia. d	Lead	Ball size	BCD	Lead angle	Root dia. d_0	Number of Circuit	Basic Load Rating N		Nut Rigidity $N/\mu m$	Nut dimension						Ball Nut Model number
								Dynamic C_a	Static C_{oa}		D	L	W	H	S	S_1	
BSR 0401	4	1	0.8	4.15	4° 23'	3.3	3.7x1	560	790	54	11	14	3	1.8	8	3	BSR 0401
BSR 0402	4	2	0.8	4.15	8° 43'	3.3	2.7x1	420	570	39	11	16	3	1.8	8	4	BSR 0402
BSR 0504	5	4	0.8	5.15	13° 53'	4.3	2.7x1	470	720	47	12	22	3	1.8	12	5	BSR 0504
BSR 0601 **	6	1	0.8	6.15	2° 58'	5.3	3.7x1	680	1200	75	13	14	3	1.8	10	2	BSR 0601 **
BSR 0602	6	2	1.0	6.20	5° 52'	5.1	2.7x1	750	1200	58	15	15	3	1.8	10	2.5	BSR 0602
BSR 0801 **	8	1	0.8	8.15	2° 15'	7.3	3.7x1	780	1650	95	16	14	3	1.8	10	2	BSR 0801 **
BSR 0802 **	8	2	1.5875	8.30	4° 23'	6.6	3.7x1	2400	4100	111	20	20	4	2.5	16	2	BSR 0802 **
BSR 0802.5	8	2.5	1.5875	8.00	5° 41'	6.3	2.7x1	1850	3000	80	16	16	3	1.8	8	4	BSR 0802.5
BSR 0805	8	5	1.5875	8.30	10° 51'	6.6	2.7x1	1850	3000	82	18	28	4	2.5	20	4	BSR 0805

Note 1) All models are Right-hand screw.

Note 2) The diameter of the Screw Shaft both ends must be less than the Screw Shaft Root diameter, because of production and Nut assembly reason.

Note 3) Ball Nut dimension is without seal at the both ends. All type of Ball Nuts cannot equip with seals.

Note 4) Rigidity

The Rigidity values shown in the table are theoretical values calculated from the amount of Elastic Displacement under the Axial load equivalent to 30% of the Basic Dynamic Load Rating C_a .

For Axial load condition other than the above, see the formula in page A823, you can calculate Rigidity using this formula.

Note 5) Stainless Rolled Ball Screw

Stainless Rolled Ball Screw is available for Ball Nut Model Number marked **.

Rolled Ball Screws

Sleeve type Single Nut

Backlash type

- Rolled Ball Screws with integrated journal are available ($\phi 12$ or less only), which have larger diameter than threaded area shown below.

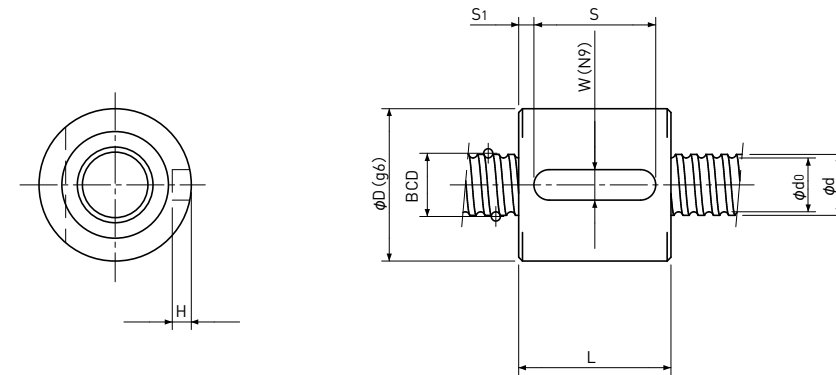
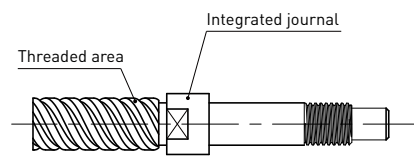

Unit:mm

Ball Nut Model number	Shaft nominal dia. d	Lead	Ball size	BCD	Lead angle	Root dia. d_0	Number of Circuit	Basic Load Rating N		Nut Rigidity $N/\mu m$	Nut dimension						Ball Nut Model number
								Dynamic C_a	Static C_{oa}		D	L	W	H	S	S_1	
BSR 1002 **	10	2	1.5875	10.30	3°32'	8.6	3.7x1	2700	5300	134	23	20	5	3	16	2.0	BSR 1002 **
BSR 1003	10	3	2.0	10.30	5°18'	8.2	3.7x1	3900	7200	140	24	26	5	3	20	3	BSR 1003
BSR 1004	10	4	2.0	10.30	7°03'	8.2	2.7x1	3000	5200	104	24	26	5	3	20	3	BSR 1004
BSR 1005	10	5	2.0	10.30	8°47'	8.2	2.7x1	3000	5200	103	23	26	5	3	16	5	BSR 1005
BSR 1006	10	6	2.0	10.30	10°30'	8.2	2.7x1	3000	5000	102	26	31	5	3	20	5.5	BSR 1006
BSR 1202	12	2	1.5875	12.30	2°58'	10.6	3.7x1	3000	6400	156	25	20	5	3	16	2	BSR1202
BSR 1402	14	2	1.5875	14.30	2°33'	12.6	3.7x1	3200	7500	176	26	20	5	3	16	2	BSR 1402
BSR 1404	14	4	2.381	14.30	5°05'	11.8	3.7x1	5700	11600	187	30	31	5	3	25	3	BSR 1404

Note 1) All models are Right-hand screw.

Note 2) The diameter of the Screw Shaft both ends must be less than the Screw Shaft Root diameter, because of production and Nut assembly reason.

Note 3) Ball Nut dimension is without seal at the both ends. All type of Ball Nuts cannot equip with seals.

Note 4) Rigidity

The Rigidity values shown in the table are theoretical values calculated from the amount of Elastic Displacement under the Axial load equivalent to 30% of the Basic Dynamic Load Rating C_a .

For Axial load condition other than the above, see the formula in page A823, you can calculate Rigidity using this formula.

Note 5) Stainless Rolled Ball Screw

Stainless Rolled Ball Screw is available for Ball Nut Model Number marked **.